

Write your name here

Surname

Other names

Edexcel

International GCSE

Centre Number

--	--	--	--	--

Candidate Number

--	--	--	--	--

Mathematics A

Paper 2F



Foundation Tier

Monday 16 January 2012 – Morning

Time: 2 hours

Paper Reference

4MA0/2F

You must have:

Ruler graduated in centimetres and millimetres, protractor, compasses, pen, HB pencil, eraser, calculator. Tracing paper may be used.

Total Marks

Instructions

- Use **black** ink or ball-point pen.
- **Fill in the boxes** at the top of this page with your name, centre number and candidate number.
- Answer **all** questions.
- Without sufficient working, correct answers may be awarded no marks.
- Answer the questions in the spaces provided
– *there may be more space than you need.*
- **Calculators may be used.**
- You must **NOT** write anything on the formulae page.
Anything you write on the formulae page will gain **NO** credit.

Information

- The total mark for this paper is 100.
- The marks for **each** question are shown in brackets
– *use this as a guide as to how much time to spend on each question.*

Advice

- Read each question carefully before you start to answer it.
- Check your answers if you have time at the end.

Turn over ►

P40611A

©2012 Pearson Education Ltd.

6/6/6



PEARSON

International GCSE MATHEMATICS

FORMULAE SHEET – FOUNDATION TIER

Pythagoras' Theorem
 $a^2 + b^2 = c^2$

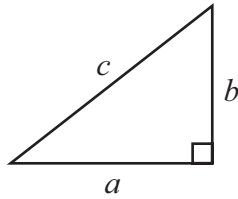

Area of a trapezium = $\frac{1}{2}(a + b)h$

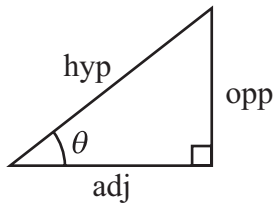
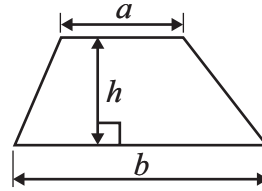

adj = hyp \times cos θ
 opp = hyp \times sin θ
 opp = adj \times tan θ

Volume of prism = area of cross section \times length

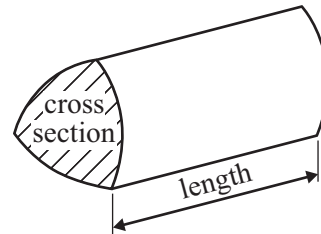

or $\sin \theta = \frac{\text{opp}}{\text{hyp}}$

$\cos \theta = \frac{\text{adj}}{\text{hyp}}$

$\tan \theta = \frac{\text{opp}}{\text{adj}}$

Circumference of circle = $2\pi r$

Area of circle = πr^2

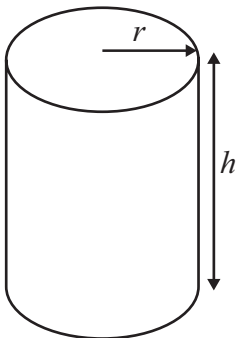

Volume of cylinder = $\pi r^2 h$

Curved surface area of cylinder = $2\pi r h$

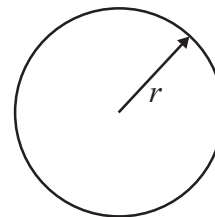

Answer ALL TWENTY THREE questions.

Write your answers in the spaces provided.

You must write down all the stages in your working.

- 1 The bar chart shows information about the number of visitors to each of five London tourist attractions in 2008.

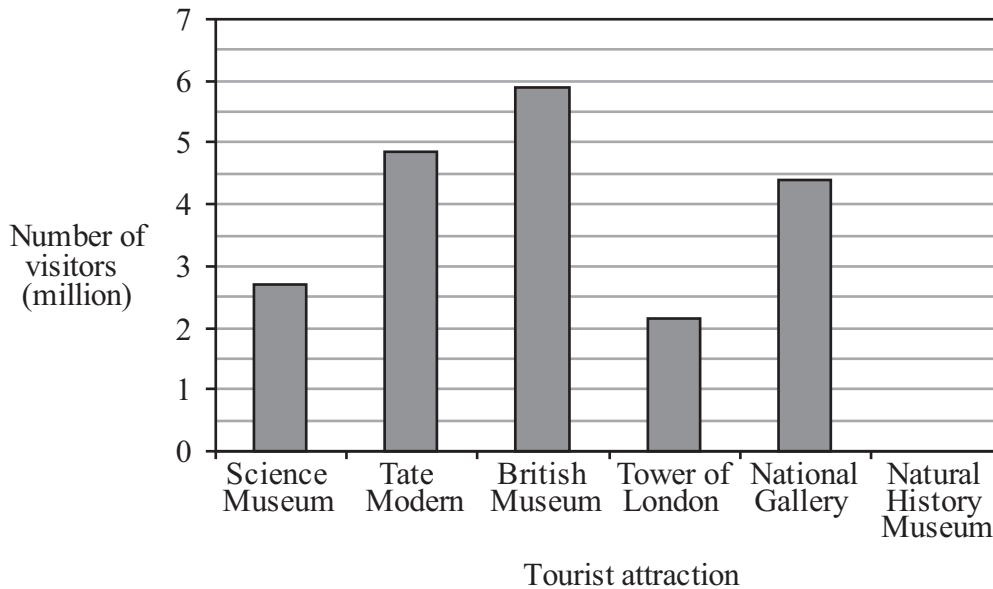

The British Museum had 5.9 million visitors.

- (a) Write down the number of visitors to the Science Museum.

..... million
(1)

- (b) Which tourist attraction had 4.4 million visitors?

.....
(1)

- (c) In 2008, the Natural History Museum had 3.7 million visitors.

Draw a bar on the bar chart to show this information.

(1)

- (d) The number of visitors to one of these tourist attractions was equal to the sum of the number of visitors to the Science Museum and the number of visitors to the Tower of London.

Which tourist attraction was this?

.....
(1)

(Total for Question 1 is 4 marks)



2 The table shows the average annual rainfall in each of six cities.

City	Average annual rainfall (millimetres)
Colombo	2345
Dhaka	1920
Freetown	3436
Kuala Lumpur	2443
Mombasa	1203
Singapore	2415

(a) Which of the cities has the highest average annual rainfall?

.....
(1)

(b) Write the number 1203 in words.

.....
(1)

(c) Write down the value of the 4 in the number 2345

.....
(1)

(d) Write the number 3436 correct to the nearest ten.

.....
(1)

(e) Which number in the table is a multiple of 10?

.....
(1)

(f) Two of the numbers in the table, when written correct to the nearest hundred, are 2400

Write down the two numbers.

..... ,
(2)

(g) Convert 1920 millimetres to metres.

..... metres
(1)

(Total for Question 2 is 8 marks)



3 (a) The diagram shows triangle ABC .

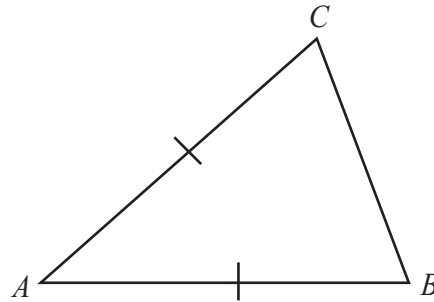

(i) $AB = AC$.

What type of triangle is triangle ABC ?

.....

(ii) On the triangle, draw the line of symmetry.

(2)

(b) (i) In the space below, draw a quadrilateral which has exactly one line of symmetry.

(ii) On the quadrilateral, draw its line of symmetry.

(iii) Write down the mathematical name of this quadrilateral.

.....

(3)

(Total for Question 3 is 5 marks)

Do NOT write in this space.



4 Here are the first five terms of a number sequence.

50 47 44 41 38

(a) Write down the next two terms of the sequence.

.....,

(2)

(b) Explain how you worked out your answer.

.....

(1)

(c) Find the 15th term of the sequence.

.....

(1)

(d) Explain why 0 cannot be a term of the sequence.

.....

(1)

(Total for Question 4 is 5 marks)

5 (a) Write $\frac{30}{45}$ as a fraction in its simplest form.

.....

(1)

(b) Work out $\frac{5}{6}$ of 48

.....

(2)

(c) Convert $\frac{7}{8}$ to a decimal.

.....

(2)

(Total for Question 5 is 5 marks)



6 (a) Write down the order of rotational symmetry of each diagram.

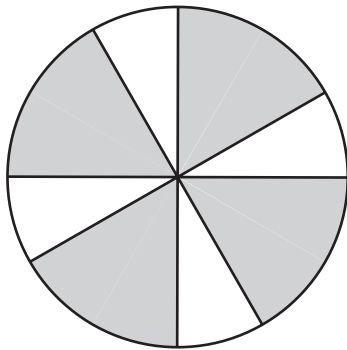

(i)

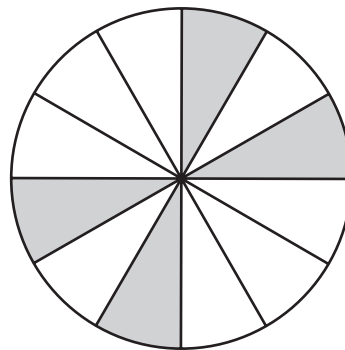

(ii)

(2)

(b) Shade 6 sectors on each diagram so that the completed diagram has rotational symmetry of

(i) order 6

(ii) order 3

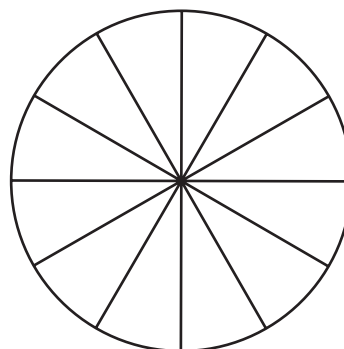
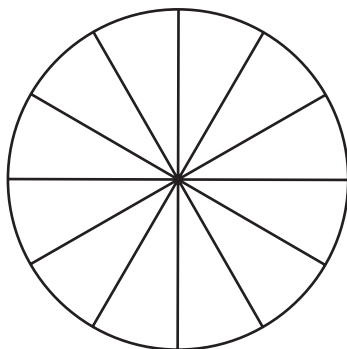

(2)

(Total for Question 6 is 4 marks)

Do NOT write in this space.



7 (a) Write down the value of the 7 in the number 26.478

.....
(1)

(b) Write these numbers in order of size.

Start with the smallest number.

0.12 0.18 0.08 0.1

.....
(1)

(c) Write 2.792 correct to 1 decimal place.

.....
(1)

(d) Find the number which is halfway between 2.7 and 3.5

.....
(1)

(e) Write 0.07 as a percentage.

..... %
(1)

(Total for Question 7 is 5 marks)

Do NOT write in this space.



8 Here are eight numbers.

2 9 7 3 6 8 9 8

Work out the mean of the numbers.

.....
(Total for Question 8 is 2 marks)

9

$$T = 3d + 4n$$

(a) Work out the value of T when $d = 2$ and $n = 5$

$$T = \text{.....}$$

(2)

(b) Work out the value of T when $d = -4$ and $n = 3.5$

$$T = \text{.....}$$

(2)

(c) Work out the value of d when $T = 9$ and $n = 6$

$$d = \text{.....}$$

(3)

(Total for Question 9 is 7 marks)

Do NOT write in this space.



10 A machine makes paper clips from a 2 metre length of wire.

Each paper clip is made from 72 mm of wire.

(i) Work out the number of paper clips the machine makes.

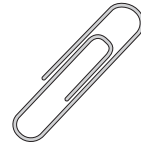

(ii) Work out the length of wire which is left over.
Give your answer in millimetres.

..... mm

(Total for Question 10 is 5 marks)

11 Work out the value of $\frac{6.7 - 2.5}{2.8 \times 0.4}$

Give your answer as a decimal.

.....
(Total for Question 11 is 2 marks)



12

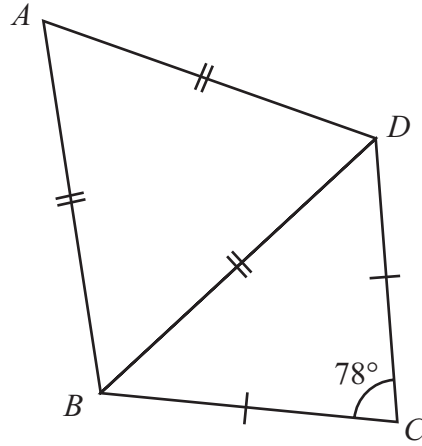

Diagram **NOT**
accurately drawn

The diagram shows a quadrilateral $ABCD$.
 $AB = BD = AD$.
 $CB = CD$.
Angle $BCD = 78^\circ$

Work out the size of angle ABC .

(Total for Question 12 is 4 marks)



13 Three positive whole numbers have a median of 7 and a mean of 5

Find the range of these three numbers.

.....

(Total for Question 13 is 3 marks)

14 An aeroplane flew from Qatar to Bahrain.

The distance flown was 135 km.

The average speed was 180 km/h.

Work out the time taken.

Give your answer in minutes.

..... minutes

(Total for Question 14 is 3 marks)

15 Solve $7x - 5 = 3x + 2$

Show your working clearly.

$x =$

(Total for Question 15 is 3 marks)



16 Here are 8 dominoes.

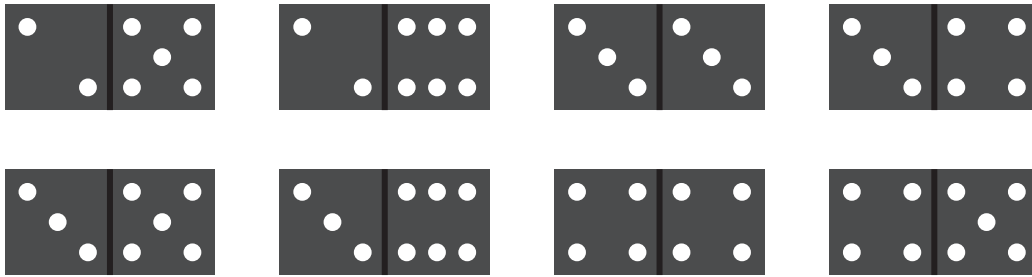

The 8 dominoes are put in a bag.

Helima takes at random a domino from the bag.

(a) Find the probability that she takes a domino with a total of

(i) more than 5 spots,

.....

(ii) 6 spots,

.....

(iii) 7 spots.

.....

(4)

Riaz takes at random a domino from the bag of 8 dominoes.

(b) Find the probability that he takes a domino with a total of 8 spots or a domino with a total of 9 spots.

.....

(2)

(Total for Question 16 is 6 marks)

Do NOT write in this space.



17 On the grid, draw the graph of $y = 4x - 1$ from $x = -2$ to $x = 4$

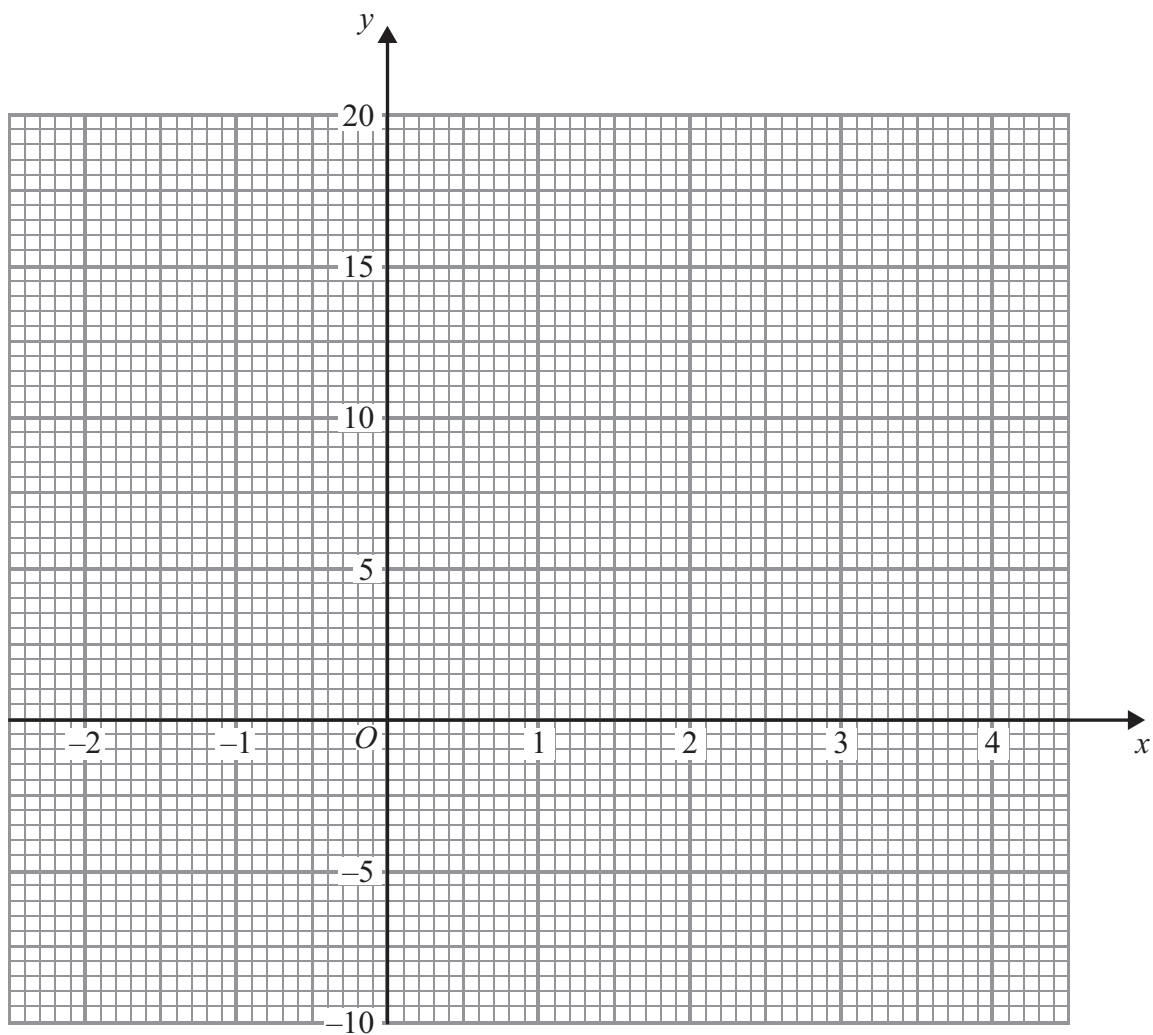

(Total for Question 17 is 4 marks)

Do NOT write in this space.



18 (a) There are 32 students in a class.

All the students are either left-handed or right-handed.

The ratio of the number of left-handed students to the number of right-handed students is 1 : 7

Work out the number of right-handed students.

.....
(2)

(b) Sajid makes a scale model of a lorry.

He uses a scale of 1 : 32

The length of Sajid's model lorry is 45 cm.

Chitra makes a scale model of the same lorry.

She uses a scale of 1 : 72

Work out the length of Chitra's model lorry.

..... cm
(3)

(Total for Question 18 is 5 marks)

Do NOT write in this space.



19

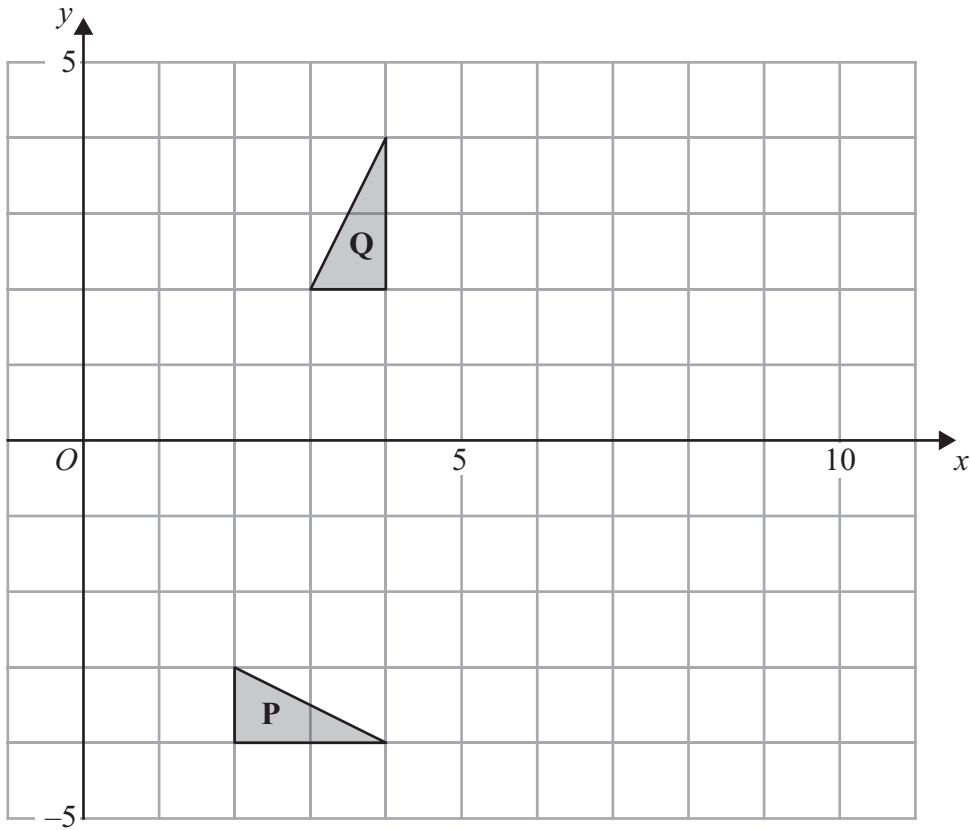

(a) Describe fully the single transformation which maps triangle **P** onto triangle **Q**.

.....
.....
(3)

(b) On the grid, translate triangle **Q** 4 squares to the right and 2 squares down.
Label the new triangle **R**.

(1)

(Total for Question 19 is 4 marks)

Do NOT write in this space.



20 Express 200 as a product of powers of its prime factors.

.....
(Total for Question 20 is 3 marks)

21 (a) Simplify $c^4 \times c^3$

.....
(1)

(b) $\frac{y^3 \times y^n}{y} = y^6$

Find the value of n .

$n =$
(2)

(Total for Question 21 is 3 marks)

Do NOT write in this space.



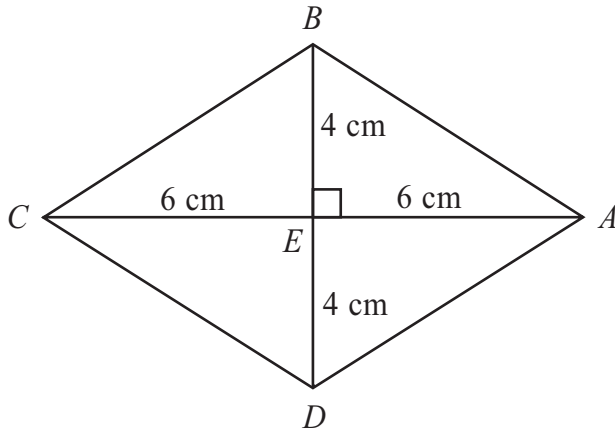

Diagram **NOT** accurately drawn

$ABCD$ is a rhombus.
 The diagonals AC and BD cross at the point E .
 $AE = CE = 6$ cm.
 $BE = DE = 4$ cm.
 Angle $AEB = 90^\circ$

(a) Work out the area of the rhombus.

..... cm²
 (3)

(b) Work out the length of AB .
 Give your answer correct to 3 significant figures.

..... cm
 (3)

(Total for Question 22 is 6 marks)



23 (i) Solve the inequalities $-6 < 4x \leq 8$

(ii) n is an integer.

Write down all the values of n which satisfy $-6 < 4n \leq 8$

(Total for Question 23 is 4 marks)

TOTAL FOR PAPER IS 100 MARKS

Do NOT write in this space.



BLANK PAGE

Do NOT write on this page.

