



UNIVERSITY OF CAMBRIDGE INTERNATIONAL EXAMINATIONS
International General Certificate of Secondary Education

CANDIDATE
NAME

CENTRE
NUMBER

--	--	--	--	--

CANDIDATE
NUMBER

--	--	--	--



PHYSICS

0625/51

Paper 5 Practical Test

October/November 2011

1 hour 15 minutes

Candidates answer on the Question Paper

Additional Materials: As listed in the Confidential Instructions

READ THESE INSTRUCTIONS FIRST

Write your Centre number, candidate number and name in the spaces at the top of the page.

Write in dark blue or black pen.

You may use a pencil for any diagrams, graphs or rough working.

Do not use staples, paper clips, highlighters, glue or correction fluid.

DO **NOT** WRITE IN ANY BARCODES.

Answer **all** questions.

At the end of the examination, fasten all your work securely together.

The number of marks is given in brackets [] at the end of each question or part question.

For Examiner's Use	
1	
2	
3	
4	
Total	

This document consists of **9** printed pages and **3** blank pages.



- 1 In this experiment, you will determine the weight of a metre rule.

Carry out the following instructions referring to Fig. 1.1.

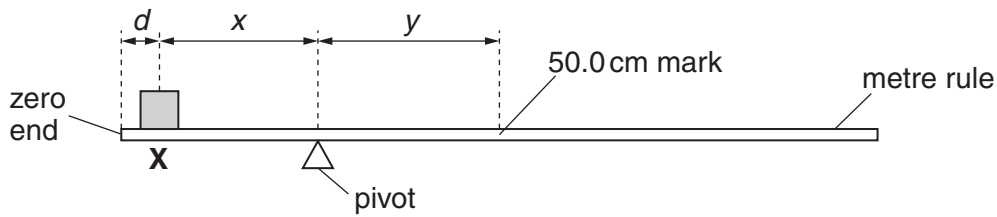

Fig. 1.1

You are provided with a 1.0 N load, labelled **X**.

- (a) (i) Place the load **X** on the rule so that its centre is at $d = 5.0$ cm from the zero end of the rule as shown in Fig. 1.1. Record the value of d in Table 1.1.
- (ii) Adjust the position of the rule so that it is as near as possible to being balanced, with the 50.0 cm mark to the right of the pivot.
- (iii) Measure, and record in the table, the distance x from the centre of the load **X** to the pivot.
- (iv) Measure, and record in the table, the distance y from the pivot to the 50.0 cm mark on the rule.
- (v) Repeat the steps (i)–(iv) using d values of 10.0 cm, 15.0 cm, 20.0 cm and 25.0 cm.

Table 1.1

d / cm	x / cm	y / cm

[2]

- (b) Plot the graph of y/cm (y -axis) against x/cm (x -axis). You do not need to include the origin (0,0) on your graph.

For
Examiner's
Use

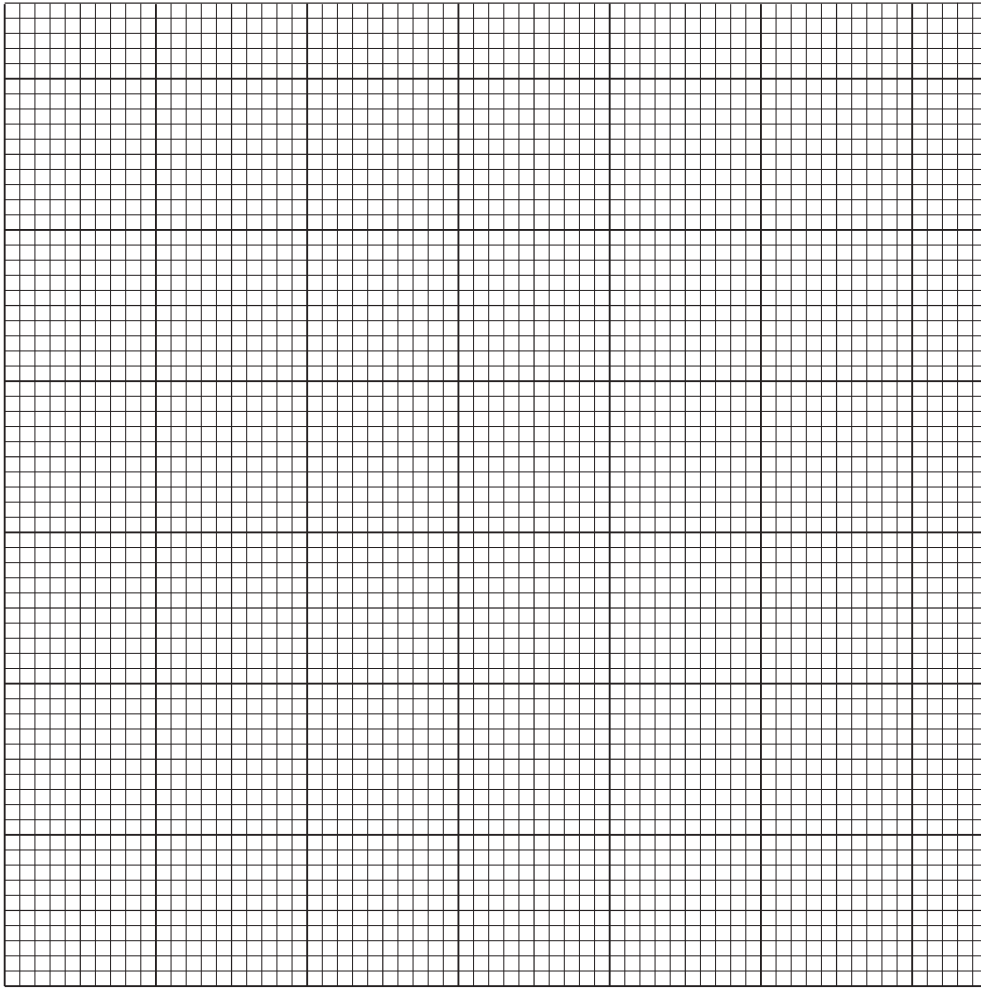

[4]

- (c) Determine the gradient G of the graph. Show clearly on the graph how you obtained the necessary information.

$$G = \dots\dots\dots [2]$$

- (d) Calculate the weight W of the metre rule using the equation $W = \frac{L}{G}$, where $L = 1.0\text{N}$.

$$W = \dots\dots\dots [2]$$

[Total: 10]

- 2 In this experiment, you will investigate temperature changes when hot water and cold water are mixed.

You are provided with a supply of hot water and a supply of cold (room temperature) water.

- (a) (i) Pour 100 cm^3 of cold water into the beaker labelled **A**.

Measure and record the temperature θ_c of the water in beaker **A**.

$$\theta_c = \dots\dots\dots$$

- (ii) Measure and record the temperature θ_h of the hot water supplied.

$$\theta_h = \dots\dots\dots$$

- (iii) Add 100 cm^3 of the hot water to the water in beaker **A**.

Measure and record the temperature θ_m of the mixture of hot and cold water.

$$\theta_m = \dots\dots\dots$$

- (iv) State two precautions that you took to ensure the reliability of your value of the temperature θ_m .

1.

.....

2.

.....

- (v) Calculate θ_{av} , the average of θ_c and θ_h .

$$\text{average } \theta_{av} = \dots\dots\dots [4]$$

(b) (i) Empty the water from beaker **A**.

(ii) Repeat the steps **(a)(i)**, **(ii)**, **(iii)** and **(v)** using 130 cm³ of cold water and 130 cm³ of hot water.

$\theta_c =$

$\theta_h =$

$\theta_m =$

average $\theta_{av} =$ [2]

(c) A student suggests that the temperature of the mixture θ_m should be the average of θ_c and θ_h .

State whether your experimental results support this suggestion and justify your statement by reference to your results.

statement

justification

.....

.....

..... [2]

(d) Suggest a practical reason in this experiment for the temperature of the mixture θ_m being different from the average value θ_{av} , even when the precautions you have stated in **(a)(iv)** have been taken.

.....

..... [1]

(e) Suggest a modification to the experiment which should reduce the difference between θ_m and θ_{av} .

.....

..... [1]

[Total: 10]

- 3 In this experiment, you will investigate the current in resistors in a circuit.

Carry out the following instructions referring to Fig. 3.1. The circuit is set up for you.

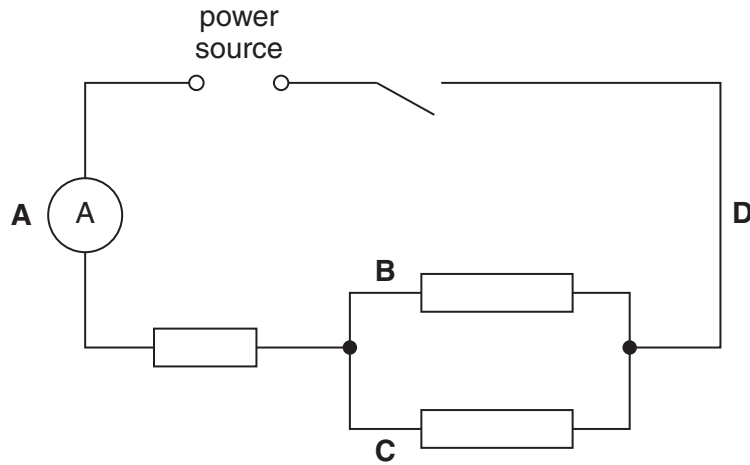

Fig. 3.1

- (a) (i) Switch on. Record the current I_A in the circuit.

$I_A = \dots\dots\dots$

Switch off.

- (ii) Change the position of the ammeter to the position marked **B** on Fig. 3.1. Switch on. Record the current I_B in the circuit.

$I_B = \dots\dots\dots$

Switch off.

- (iii) Change the position of the ammeter to the position marked **C** on Fig. 3.1. Switch on. Record the current I_C in the circuit.

$I_C = \dots\dots\dots$

Switch off.

- (iv) Change the position of the ammeter to the position marked **D** on Fig. 3.1. Switch on. Record the current I_D in the circuit.

$I_D = \dots\dots\dots$ [4]

Switch off.

(b) Theory suggests that $I_A = I_B + I_C$ and $I_D = I_B + I_C$.

(i) Calculate $I_B + I_C$.

$$I_B + I_C = \dots\dots\dots$$

(ii) State whether your experimental results support the theory and justify your statement by reference to your results.

statement

justification

.....

.....[3]

(c) (i) Connect the voltmeter so that it measures the potential difference V across the combination of the three resistors. Record the potential difference V .

$$V = \dots\dots\dots$$

(ii) Calculate the resistance R of the combination of the three resistors using the equation $R = \frac{V}{I}$.

$$R = \dots\dots\dots[2]$$

(d) On Fig. 3.1, draw in the voltmeter connected as described in (c)(i) using the standard symbol for a voltmeter. [1]

[Total: 10]

For
Examiner's
Use

- 4 In this experiment, you will investigate the reflection of light by a plane mirror.

Carry out the following instructions referring to Fig. 4.1.

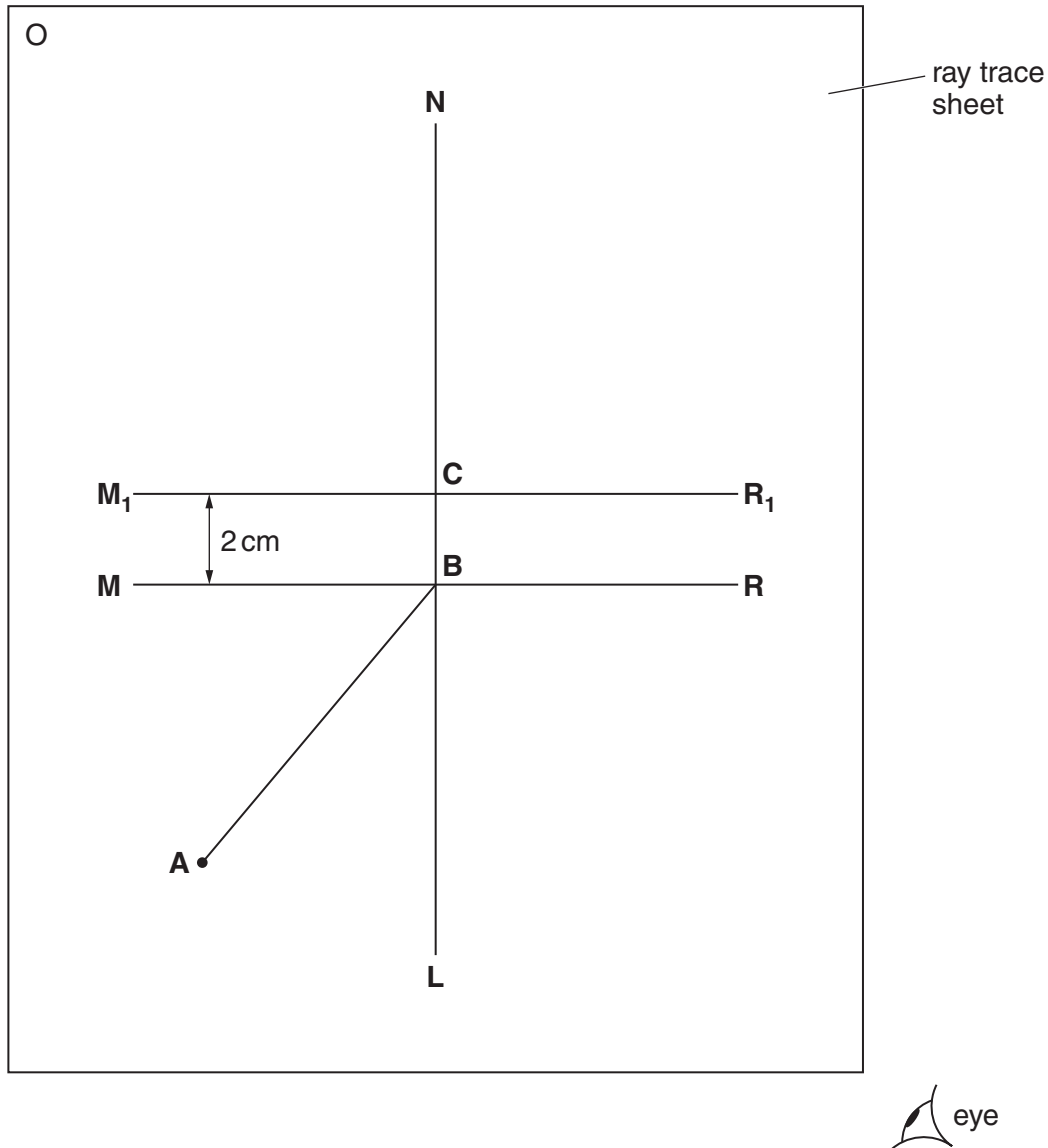

Fig. 4.1

- (a) Draw a line 10cm long near the middle of the ray trace sheet. Label the line **MR**. Draw a normal to this line that passes through its centre. Label the normal **NL**. Label the point at which **NL** crosses **MR** with the letter **B**.
- (b) Draw a line 8cm long from **B** at an angle of incidence $i = 40^\circ$ to the normal below **MR** and to the left of the normal. Label the end of this line **A**. Record the angle of incidence i in Table 4.1.
- (c) Place the mirror, with its reflecting face vertical, on the line **MR**. The mirror has a line drawn on it. One end of this line must be at point **B**.
- (d) Place a pin P_1 at **A**.

- (e) View the line on the mirror and the image of pin P_1 from the direction indicated by the eye in Fig. 4.1. Place two pins P_2 and P_3 some distance apart so that pins P_3 , P_2 , the image of P_1 , and the line on the mirror all appear exactly one behind the other. Label the positions of P_2 and P_3 .
- (f) Remove the pins and the mirror and draw in the line joining the positions of P_2 and P_3 . Continue the line until it meets the normal.
- (g) Measure, and record in the table, the angle of reflection r between the normal and the line passing through P_2 and P_3 .

Table 4.1

$i/^\circ$	$r/^\circ$

[3]

- (h) Draw a line parallel to **MR** and 2 cm above it. Label the line **M_1R_1** . Label the point at which **NL** crosses the line with the letter **C**.
- (i) Draw a line from **A** to **C**. Measure, and record in the table, the angle of incidence i between line **AC** and the normal.
- (j) Place the mirror, with its reflecting face vertical, on the line **M_1R_1** . One end of the line on the mirror must be at point **C**.
- (k) Repeat the steps (d)–(g).
- (l) In spite of carrying out this experiment with reasonable care, it is possible that the values of the angle of reflection r will not be exactly the same as the values obtained from theory. Suggest two possible causes of this inaccuracy.

1.
.....

2.
..... [2]

Tie in your ray trace sheet between pages 10 and 11. [5]

[Total: 10]

BLANK PAGE

Permission to reproduce items where third-party owned material protected by copyright is included has been sought and cleared where possible. Every reasonable effort has been made by the publisher (UCLES) to trace copyright holders, but if any items requiring clearance have unwittingly been included, the publisher will be pleased to make amends at the earliest possible opportunity.

University of Cambridge International Examinations is part of the Cambridge Assessment Group. Cambridge Assessment is the brand name of University of Cambridge Local Examinations Syndicate (UCLES), which is itself a department of the University of Cambridge.